

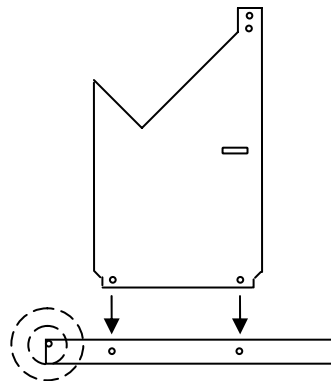


R & V WORKS

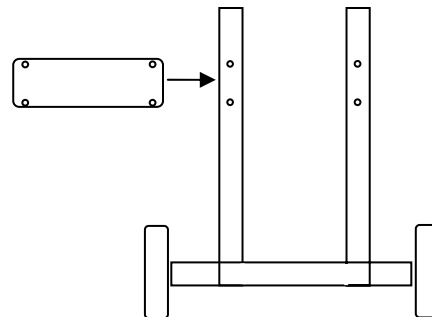


TABLE ASSEMBLY INSTRUCTIONS

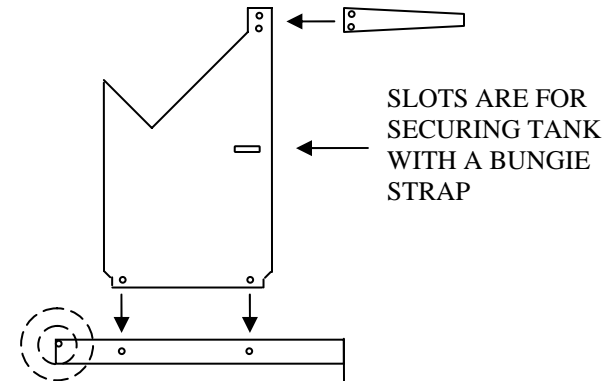
STEP 1. BOLT BOTH SIDE PLATES TO THE SKID ASSY AS SHOWN.



STEP 2. BOLT THE FRONT BRACE PLATE TO THE SIDE PLATES ON THE WHEEL END OF SKID AS SHOWN.



STEP 3. BOLT THE TABLE TOP TO THE SIDE PLATES AS SHOWN



TOOLS REQUIRED:

1. 7/16 WRENCH
2. PHILLIPS SCREWDRIVER